

Product Summary

The GESDBL5V0D51 is designed to protect voltage sensitive electronic components from ESD and other transients. Excellent clamping capability, low leakage, low capacitance, and fast response time, make these parts ideal for ESD protection on designs where board space is at a premium. Because of its small size, it is suited for use in digital cameras, cellular phones, MP3 players and many other portable applications where board space is at a premium.

Feature

- Low reverse stand-off voltage: 5V Max.
- Low reverse clamping voltage
- Ultra-low leakage current
- Fast response time
- IEC 61000-4-2 Level 4 ESD protection

Application

- Digital cameras
- Portable applications
- Audio and video equipment
- MP3 players
- Mobile phone

Marking:



Front Side
B5=Device Code

SOD-523

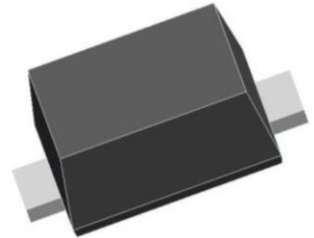

Schematic diagram

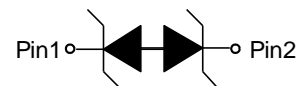

Absolute Maximum Ratings ($T_a=25^{\circ}\text{C}$ unless otherwise noted)

Parameter	Symbol	Value	Unit
IEC 61000-4-2 ESD Voltage Air Model	V_{ESD}	± 30	kV
IEC 61000-4-2 ESD Voltage Contact Model		± 30	
JESD22-A114-B ESD Voltage Per Human Body Model		± 16	
ESD Voltage Machine Model		± 0.4	
Peak Pulse Power (8/20 μs)	P_{pk}	100	W
Peak Pulse Current (8/20 μs)	I_{PP}	8	A
Junction Temperature	T_{J}	-55~ +125	$^{\circ}\text{C}$
Storage Temperature	T_{stg}	-55~ +150	$^{\circ}\text{C}$

Contact discharge current waveform per IEC61000-4-2

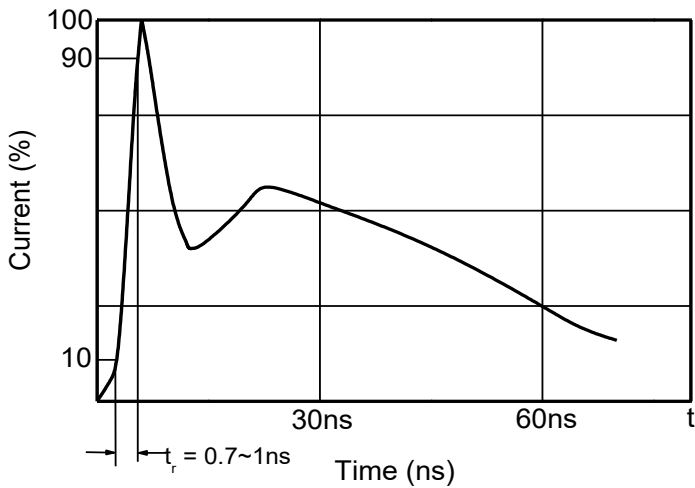

8/20 μs waveform per IEC61000-4-5

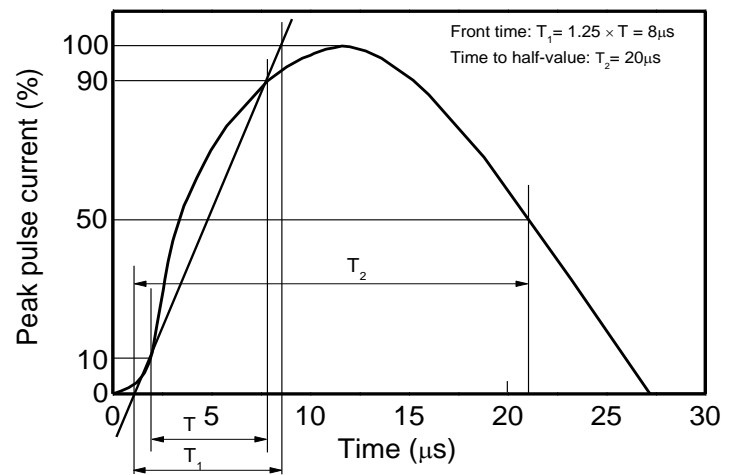

Electrical Parameter

Symbol	Parameter
V _C	Clamping Voltage @ I _{PP}
I _{PP}	Peak Pulse Current
V _{BR}	Breakdown Voltage @ I _{BR}
I _{BR}	Test Current
I _R	Reverse Leakage Current @ V _{RWM}
V _{RWM}	Reverse Standoff Voltage

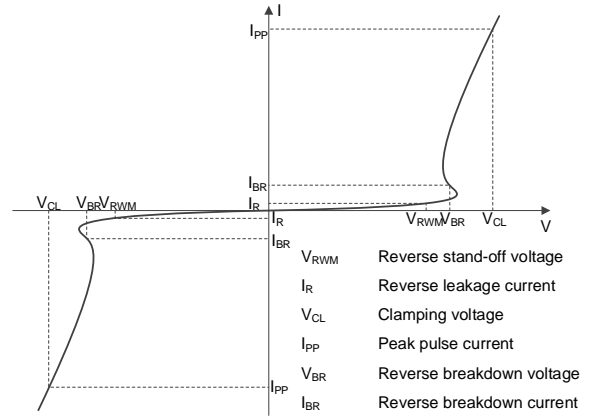

V-I characteristics for a Bi-directional TVS

Electrical Characteristics (T_a=25°C unless otherwise specified)

Parameter	Symbol	Test conditions	Min	Typ	Max	Unit
Reverse stand-off voltage	V _{RWM} ¹⁾				5	V
Reverse leakage current	I _R	V _{RWM} =5V			0.5	μA
Breakdown voltage	V _(BR)	I _T =1mA	5.6		7.4	V
Clamping voltage	V _{C1} ²⁾	I _{PP} = 1A		7	8	V
	V _{C2} ²⁾	I _{PP} = 8A		10	12.5	V
Junction capacitance	C _J	V _R =0V, f=1MHz		17	22	pF

1) Other voltages available upon request.

2) Non-repetitive current pulse 8/20us exponential decay waveform according to IEC61000-4-5

Typical Characteristics

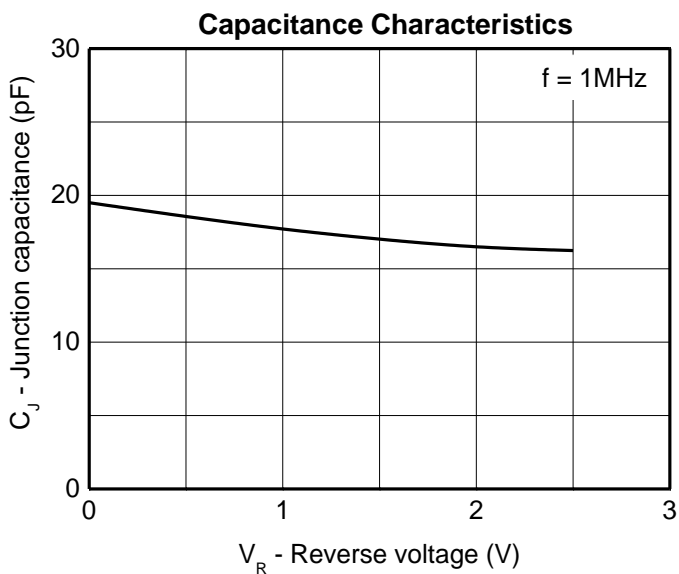
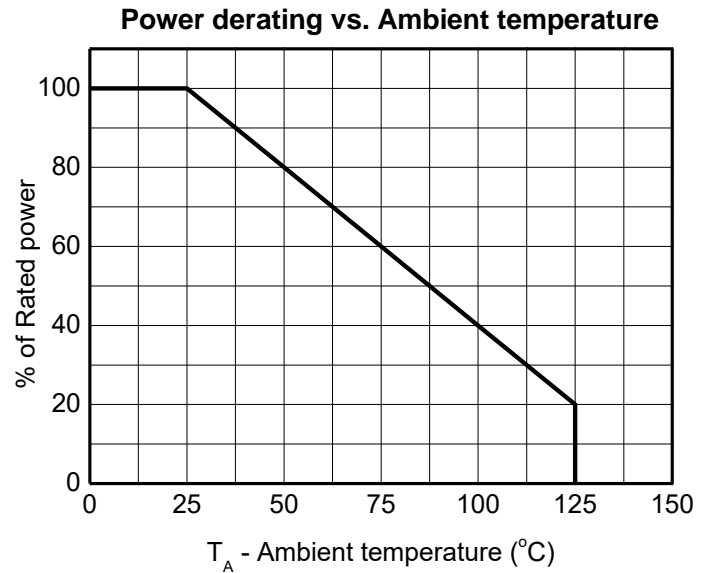
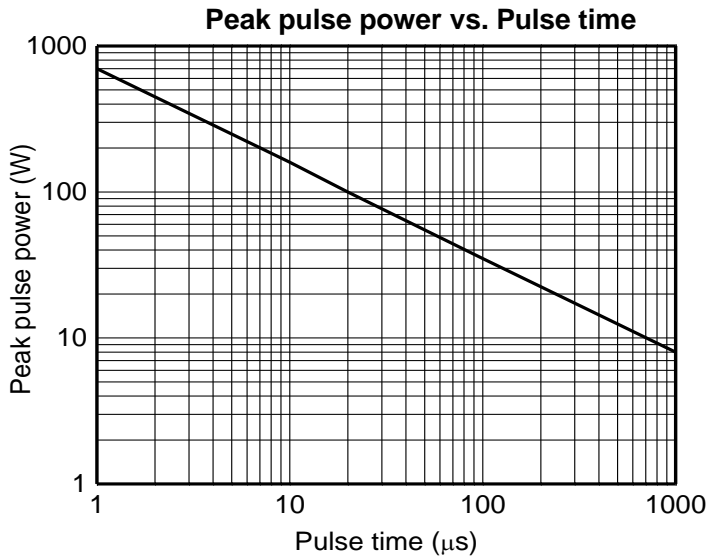
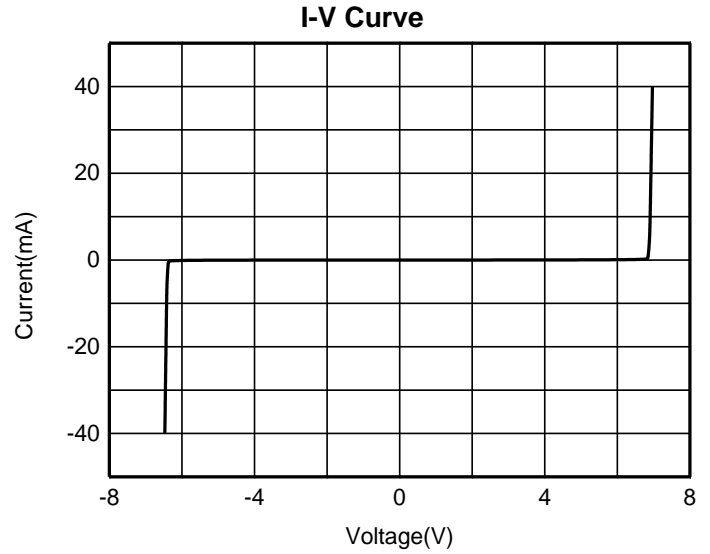
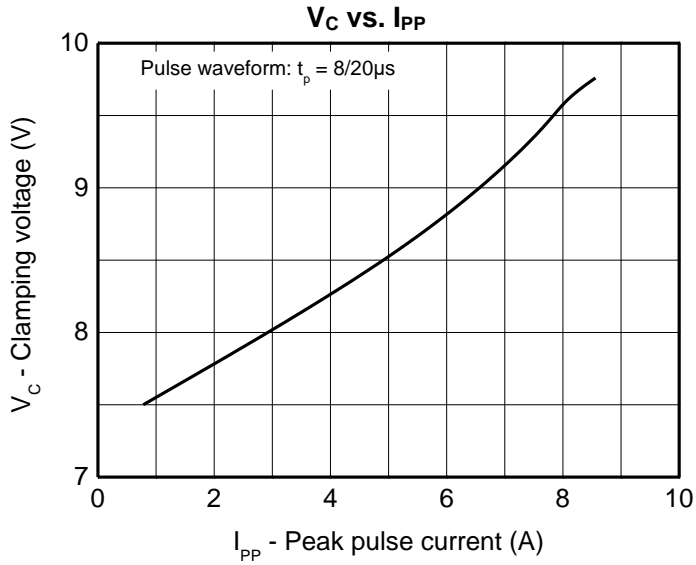

SOD-523 Package Outline Dimensions

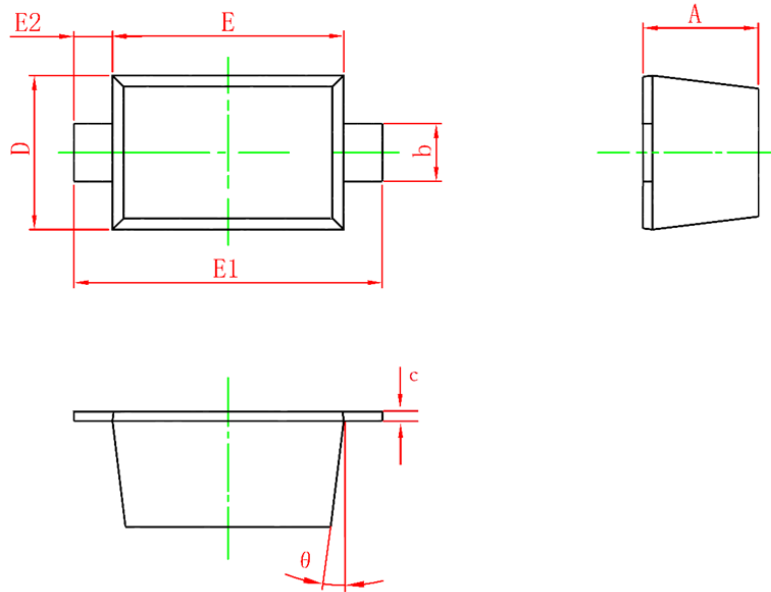

Symbol	Dimensions In Millimeters		Dimensions In Inches	
	Min.	Max.	Min.	Max.
A	0.470	0.770	0.018	0.030
b	0.250	0.350	0.010	0.014
c	0.080	0.150	0.003	0.006
D	0.750	0.850	0.030	0.033
E	1.100	1.300	0.043	0.051
E1	1.500	1.700	0.059	0.067
E2	0.200REF		0.008REF	
θ	7°REF		7°REF	